

# BRU3 - Site Requirements

## Contents

1	Introduction.....	3
1.1	The Mobitex System.....	3
1.2	BRU3 Presentation.....	4
1.2.1	Technical Performance.....	5
2	Preparations Before Installation.....	7
2.1	Storage.....	7
2.2	Transport.....	7
2.3	Before Installation.....	7
2.3.1	Material and Tools That Are Not Provided by Mobitex Technology AB.....	8
2.4	Space Required.....	9
2.4.1	General.....	10
2.4.2	Above the BRU3.....	10
2.4.3	Below the BRU3.....	10
2.4.4	On both sides of the BRU3.....	11
2.4.5	In front of the BRU3.....	11
2.4.6	Installation Alternatives.....	11
3	Power Requirements.....	14
4	Cables and External Connections.....	15
4.1	General.....	15
4.2	Connecting Power.....	17
4.3	Connecting Network Communication.....	20
4.3.1	Integrated V.32 Telephone Modem.....	22
4.3.2	Unbalanced serial port, RS 232C.....	23
4.3.3	Balanced serial port, RS 422B.....	25
4.4	Connecting the Alarm.....	27
4.4.1	Alarm Loop for Customer's Use.....	28
4.5	Connecting the Antenna.....	29
5	Grounding.....	31
6	Connecting Antenna Cables and Mounting Antennas.....	32
7	Lightning Protection.....	35

*Mobitex is a registered trademark of Mobitex Technology AB.*

*The contents of this document are subject to revision without notice due to continued progress in methodology, design and manufacturing.  
Mobitex Technology AB shall have no liability for any errors or damages of any kind resulting from the use of this document.*

# 1 Introduction

This document covers the site preparations to be made before the Mobitex Base Radio Unit 3 (BRU3) is installed, in terms of space required, power consumption, environmental data, cables, grounding, antenna etc. The instructions in the *BRU3 - Installation* module should be followed when installing the BRU3.

Before installation takes place, the site should be prepared in accordance with what is described in this document. This is important not only for a correct and safe installation, but also for saving time.

## 1.1 The Mobitex System

Mobitex is a digital packet switching network for data, text and status communication. Subscriber terminals can be either fixed or mobile. The network includes services for emergency (alert) messages. The nodes in the network are connected to each other in a strictly hierarchical structure.

The mobile terminals communicate by radio with the radio base stations, which are connected to an area exchange. Each area exchange is upwards connected to a main exchange, which can be found at one or more levels. The main exchange at the highest level, also referred to as the top node, connects the network to the Network Control Centre (NCC). The network is supervised from the NCC and this is also where the subscription information is entered into the system.

The fixed terminals, which are connected directly to an area exchange, consist of terminals or computers.

## 1.2 BRU3 Presentation

Base Radio Unit 3 (BRU3) is a complete one-channel compact radio base station which uses 8 kbps data signalling and is designed for the 400, 800 and 900 MHz band. The BRU3, which may be installed outdoors or indoors, is a link between the mobile terminals (MOB) and the area exchanges (MOX) in the Mobitex Network.

The BRU3 contains logic, modem units, radio units, a power supply unit including AC/DC and DC/DC converters, a battery backup and a heating unit.

All parts are integrated in the case shown below. The BRU3 is equipped with connections for antenna, power, line, modem, alarms and console terminal.

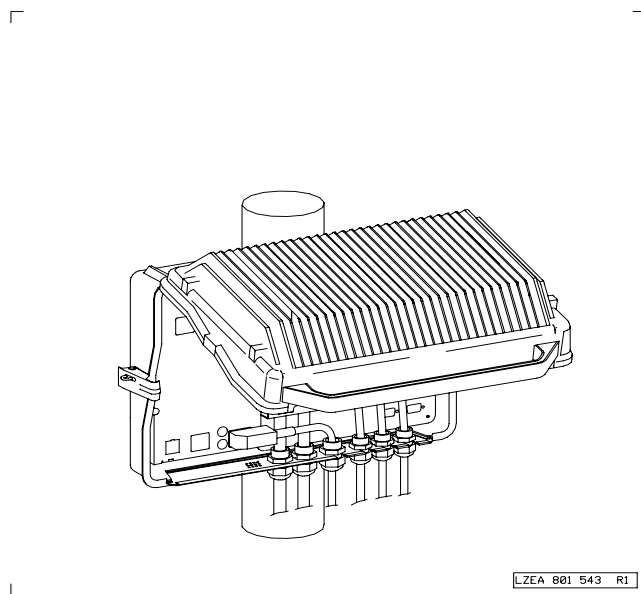

Figure 1 BRU3 pole installation.

## 1.2.1 Technical Performance

### BRU3 Dimensions

Width: 472 mm

Height : 345 mm (incl. 40 mm handle)

Depth: 202 mm

Weight 39xx: 18 kg

38xx 18 kg

34xx: 19 kg

### Environmental Classifications

#### Water resistant:

Europe class IP 43 according to IEC  
: 529

US: class 3R according to UL 50

#### Weather-Protected Locations:

ETS 300 019-1-3: Environmental Class 3.3, with extended temperature range for 34xx.

39xx: -25 °C to +55 °C

38xx -25 °C to +55 °C

34xx: -33 °C to +55 °C

**Non-Weather-Protected Locations:**

ETS 300 019-1-4: Environmental Class 4.1 with extended temperature range for 34xx.

39xx: -25 °C to +40 °C

38xx -25 °C to +40 °C

34xx: -33 °C to +40 °C

---

## 2 Preparations Before Installation

Generally, the BRU3 can be installed at most locations, both in- and outdoors. However, it is important that the BRU3 is always mounted on the Base Plate included in the FE Installation Kit.

### 2.1 Storage

The BRU3 delivery package is made according to the ETS 300 019-1-1 standard, class 1.3 for storage. It is recommended to have plans for long term storage verified by Mobitex Technology AB.

### 2.2 Transport

The BRU3 is to be transported in accordance with the ETS 300 019-1-2 standard, class 2.3 for public transportation. It is recommended to have plans for long term storage verified by Mobitex Technology AB.

### 2.3 Before Installation

On delivery, all components in the BRU3 are installed. Only the external cables for power, the lines and the antenna feeder are to be plugged into the BRU3 on installation.

By ordering all peripheral equipment before the BRU3 is delivered, you will be able to prepare the site for faster installation and commissioning of the BRU3. Contact your local Mobitex Technology AB company for further information.

### 2.3.1 Material and Tools That Are Not Provided by Mobitex Technology AB

Below is specified the material and tools that will **not** be delivered by Mobitex along with the BRU3:

- Network Communication Connection Box.
- Bolts (4 pcs of M10x70mm) for wall mounting of the Base Plate and Bolt Expanders 4 pcs (type HILTI HDE M10). Used for wall mounting only.
- Copper Grounding Cable  $\geq 16\text{mm}^2$  (AWG 5) and Cable Lug (M8).
- Antenna equipment.
- Antenna Cable RG 214/U-60 (outer diameter 10.8 mm) and a feeder (for example FLEXWELL 7/8" or 1 5/8").
- A Suhner crimp tool kit, 76 Z-0-0-15, used for mounting Suhner 11 TNC-50-7-2c connectors to the RG 214/U-60 antenna cable.
- Sealing material for antenna cable connectors.
- Cable ties.
- Padlocks for locking the BRU3.

Please refer to the *BRU3 - Installation* module for details and instructions.



## 2.4 Space Required

When deciding where to install the BRU3, it is important to keep in mind that:

- Accessibility must be maintained to allow for installation and maintenance.
- The longer the feeders and communication cables are, the higher the attenuation will be.
- The site shall provide an ambient temperature preventing the BRU3 to exceed its maximum operation temperature. The ambient temperature shall be measured 100 mm below the handle.

The space required for a BRU3 is shown in *Figure 2 “Space required.”*. Also refer to the text below for further information.

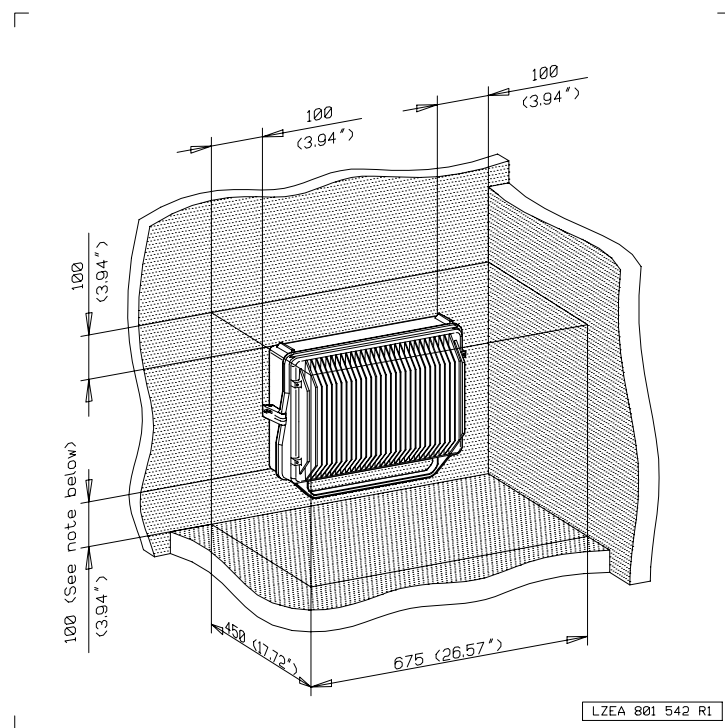

*Figure 2 Space required.*

**Note:** To facilitate service procedures, the BRU3 may be mounted more than 100 mm above the “floor”. Due to legal requirements, at outdoor installations the BRU3 must not be mounted closer than 500 mm to a horizontal or inclined surface which might allow water to splash into the cable inlet.

### 2.4.1 General

The space specified in this document is a minimum to allow an adequate airflow around the equipment. The customer decides if any additional working space is needed around the BRU3.

### 2.4.2 Above the BRU3

Minimum: 100 mm

To allow opening of the top cover, 100 mm of free space is necessary above the case. If the top cover is to be replaceable without having to dismount the case, 300 mm of free space above the case is required.

### 2.4.3 Below the BRU3

Minimum, indoor: 100 mm \*

Minimum, outdoor: 500 mm \*

\* Please refer to the note above.

To be able to run the cables safely, 100 mm of free space is necessary below the case. Several BRU3 cases can be installed together, one above the other.

For outdoor installations, refer to the note above.

#### **2.4.4 On both sides of the BRU3**

Minimum: 100 mm

To allow opening of the padlocks on each side, 100 mm of free space is necessary on both sides of the case.

#### **2.4.5 In front of the BRU3**

Minimum: 450 mm, excluding working space

To allow opening of the top cover, 450 mm of space from the wall or the pole behind the case is necessary. The specified distance of 450 mm does not include working space.

#### **2.4.6 Installation Alternatives**

The common BRU3 installation alternatives are:

- Wall installation
- Horizontal pole installation (pole diameter 15-100 mm)
- Vertical pole installation (pole diameter 15-100 mm)

The BRU3 must always be mounted on the Base Plate, included in the FE Installation Kit (FIK) NTMA 102 22/1.

If the BRU3 is to be installed on a pole, the FE Mounting Bracket 100, NTMA 102 23/1, should be used.

If none of the above installation alternatives is usable, other arrangements have to be made so that the Base Plate can be used.

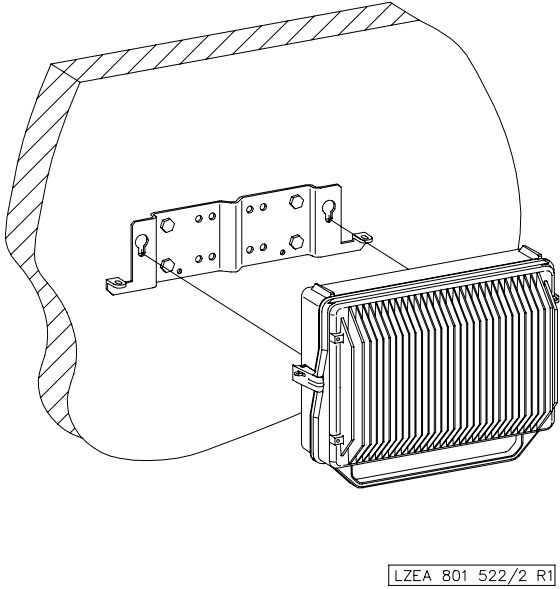

Figure 3 Wall installation.

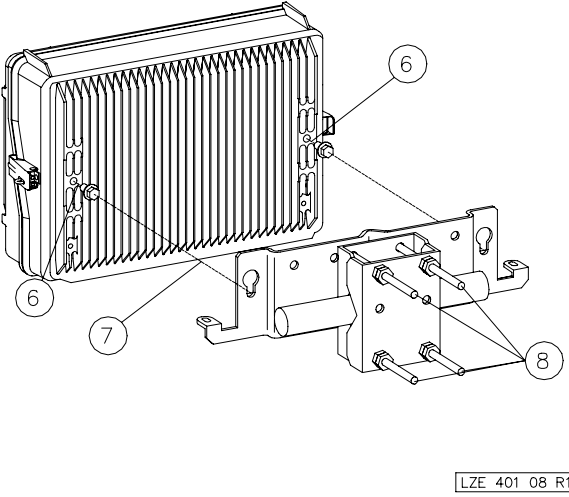
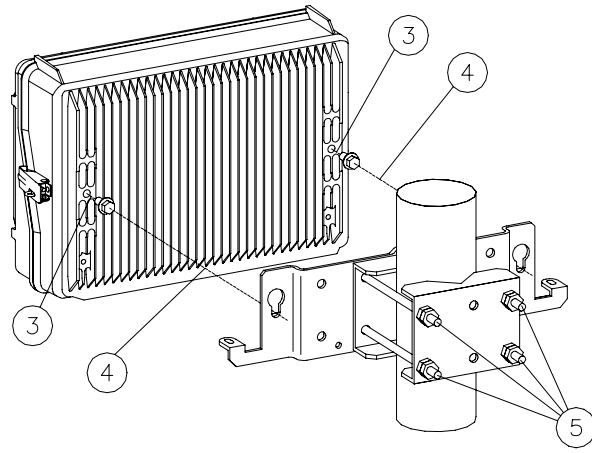

Figure 4 Horizontal pole installation.



LZEA 801 511 R2

Figure 5 Vertical pole installation.

### 3 Power Requirements

The BRU3 is supplied with 120 or 230 V AC with the following characteristics:

**39xx and 38xx:**

Voltage:	120 V AC or 230 V AC
Voltage variation:	90 - 140 V AC or 198 - 254 V AC
Nominal voltage:	110 - 130 V AC or 220 - 240 V AC
Frequency:	50/60 Hz
Site Fuse:	10 A (The site fuse is to be provided by the customer.)
Power Consumption:	Max. 500 W

**34xx:**

Voltage:	230 V AC
Voltage variation:	198 - 254 V AC
Nominal voltage:	220 - 240 V AC
Frequency:	50/60 Hz
Site Fuse:	10 A (The site fuse is to be provided by the customer.)
Power Consumption:	Max. 900 W

**Note:** BRU3 is not intended for use in an “IT power distribution system”, please refer to *IT Power System* in the *Safety Instructions* section.

## 4 Cables and External Connections

### 4.1 General

All cables provided by the customer must be in position and ready to be connected to the BRU3 before the installation takes place.

Each cable delivered by Mobitex Technology AB is equipped with a connector at the BRU3 end. The other end is delivered without a connector, which means that the operator can choose any suitable connector or socket. The power and console cables are delivered with connectors at all ends.

Make sure that the site has been prepared with both the connection block and the suitable connectors for the cables, before the installation takes place.

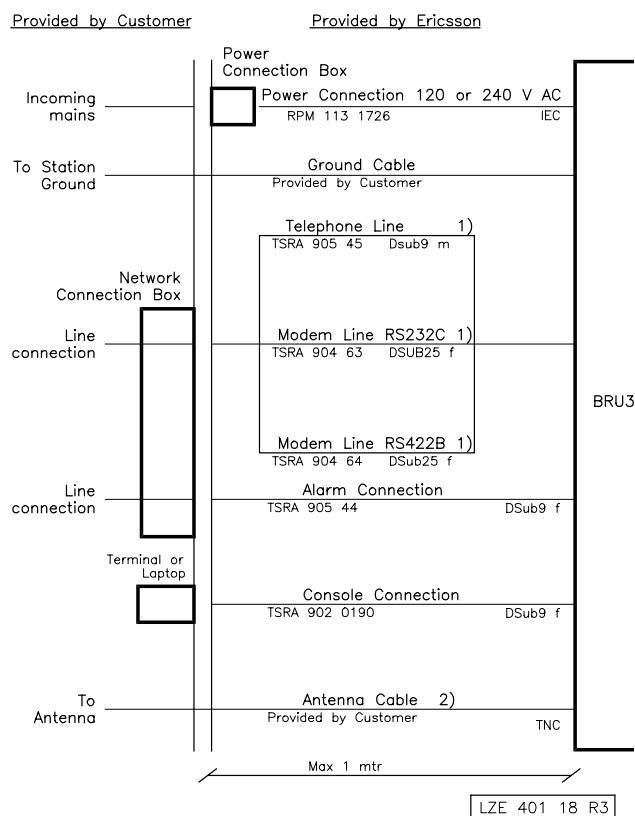

Figure 6 Cable to be provided by the customer.

1. Only one of the Line communication cables may be used.

2. One antenna cable, if duplex filter is installed.  
Two antenna cables, if bandpass filter is installed.  
Feeder loss is recommended to equal or be less than 2 dB.

**Note:** The Ground and Antenna cables are to be provided by the customer.

*Figure 7 “BRU3 external connections.”* shows where to connect the BRU3 cables. Use the figure to plan the cable arrangements. The types of connector mentioned in the following sections always correspond to the cable connector to the BRU3.

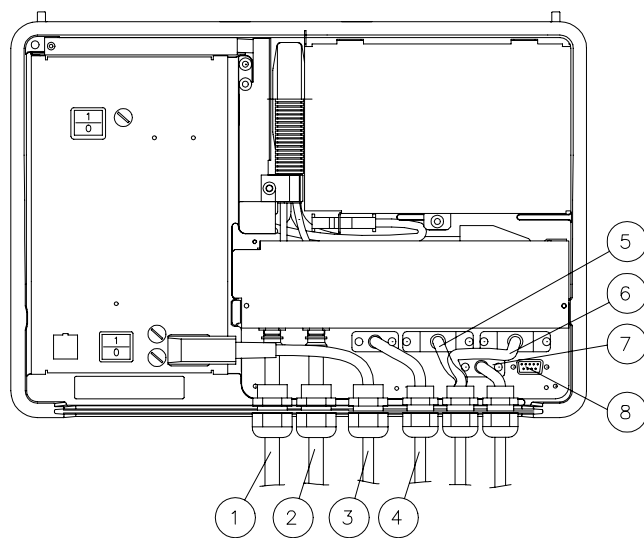

LZEA 801 534/2 R2

*Figure 7 BRU3 external connections.*

**Pos. Function**

- |   |   |
|---|---|
| 1 | Antenna Connector, Rx                   |
| 2 | Antenna Connector, Tx or Combined Rx/Tx |
| 3 | Power Connection                        |
| 4 | Telephone Line Connection               |
| 5 | Modem Connection RS 422B                |



- 6 Modem Connection RS 232C
- 7 Alarm Connection
- 8 Console Connection

The console connection is not described in the following sections.

## 4.2 Connecting Power

The Power Connection Kit is used to connect the BRU3 to the mains (Outdoor: 39xx and 38xx - No NTM 201 1126/1, 34xx - No NMT 201 1127/1). The kit includes a Power Supply Cable, a Connection Box (of the weather-protected type) and a Protection Tube (a field wiring terminal and a non-metallic, liquid-proof conduit for outdoor use).

A 120 or 230 V AC cable is used for the power supply. At the BRU3 end of the power supply cable there is an IEC connector which should be plugged into the BRU3. The other end should be connected to the mains via the connection box, according to *Figure 8 "Power connection - 39xx."*

### 39xx and 38xx:

Cond'r	Cable	Colour	Size
PE	Ground (safety) lead	Green or green/yellow	1.5 mm <sup>2</sup> (AWG16)
L1	Line	Black	1.5 mm <sup>2</sup> (AWG16)
N	Neutral	White	1.5 mm <sup>2</sup> (AWG16)

### 34xx:

Cond'r	Cable	Colour	Size
--------	-------	--------	------

PE	Ground (safety) lead	Green/yellow	1.5 mm <sup>2</sup> (AWG16)
L1	Line	Brown	1.5 mm <sup>2</sup> (AWG16)
N	Neutral	Blue	1.5 mm <sup>2</sup> (AWG16)

The maximum length of the cable between the BRU3 and the power connection box should not exceed 1 m.

When the site has been prepared for installation, there should be a weather-protected, non-live power supply cable installed, ready to be connected to the BRU3 power connection box.

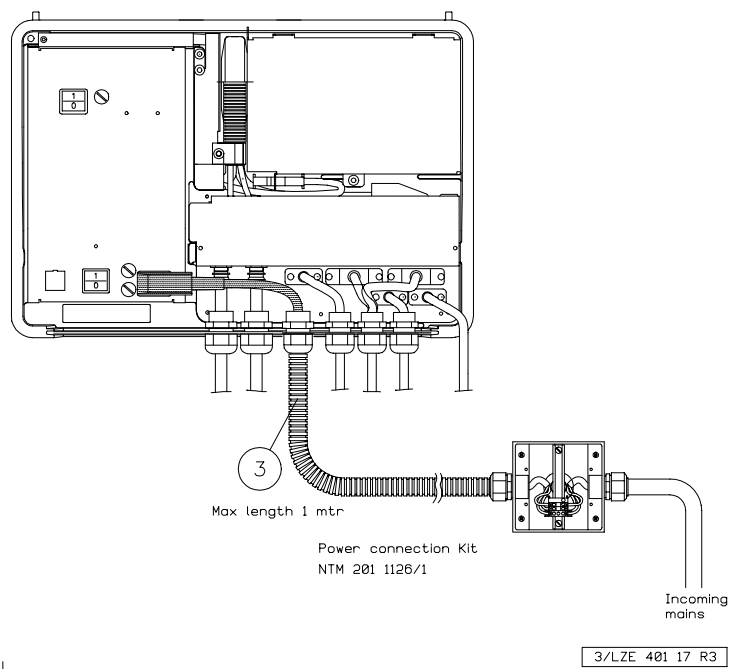

Figure 8 Power connection - 39xx.

Pos.	Function	BRU3 End Connector
------	----------	--------------------

3 Power Connection IEC, female

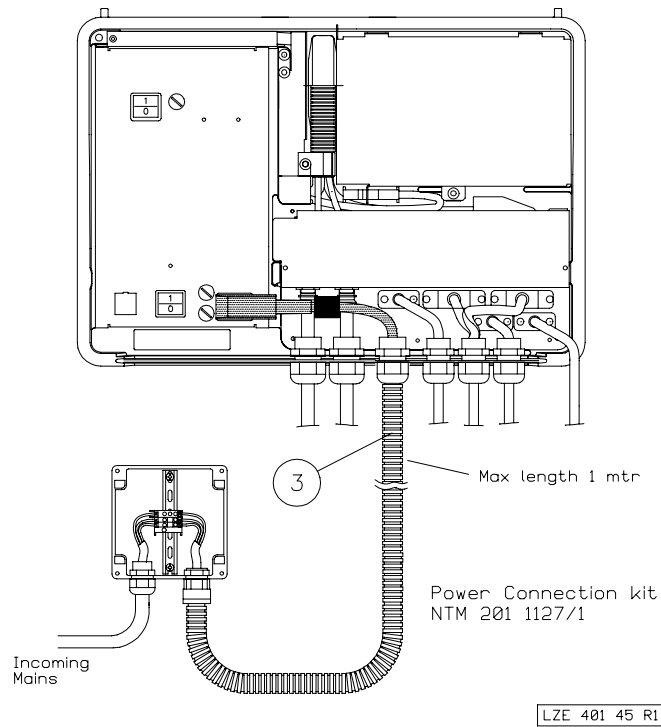

Figure 9 Power connection - 34xx.

Pos.	Function	BRU3 End Connector
3	Power Connection	IEC, female

### 4.3 Connecting Network Communication

Cables for network communication to the MOX are available for RS 232C, RS 422B and telephone line communication. Therefore, the BRU3 is equipped with three different connectors. Only one alternative can be used at a time.

An alarm interface is also available.

The network communication cable from the BRU3 must be connected to a socket. When installed outdoors, the socket should be housed in a connection box of the weather-protected type, which is to be provided by the customer.

The socket must allow for between 6 and 20 connections depending on the type of line communication used, as specified below in *Figure 10 "Network communication connection."* (*min*: Telephone only, *max*: RS 422B and Alarm). The minimum socket connection area for all wires is 0.22 mm<sup>2</sup>.

The maximum length of the cable between the BRU3 and the communication connection box should not exceed 1 m. The cable diameter for all network communication cables is 8 mm.

Specifications for each cable, which are found in the following sections, can be used for correct installation of the cables to the connection block.

When the site has been prepared for installation, there should be a weather-protected (at outdoor locations) network communication box installed where the network communication cable will be connected.

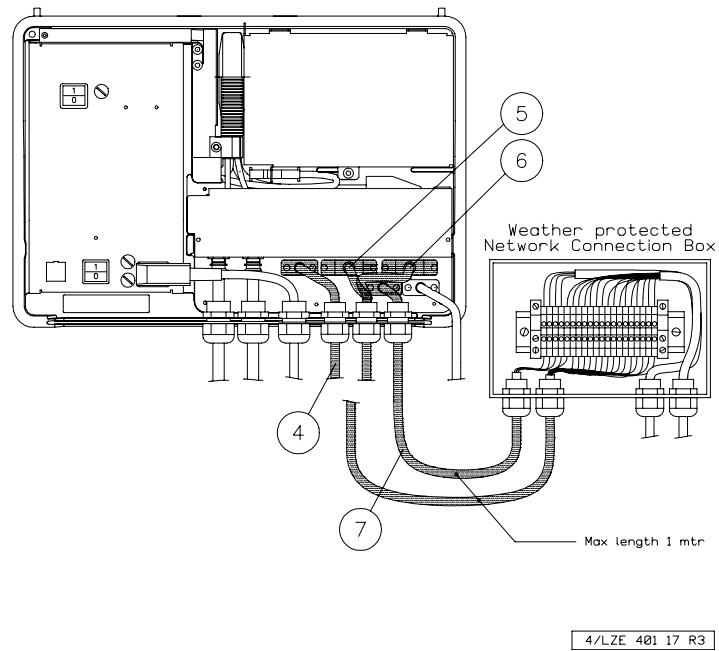

Figure 10 Network communication connection.

Pos	Function	BRU3 End Connector	No. of plinth connections
4	Telephone Line Connection	D-SUB 9-pole, male	6
5	Modem Connection RS 422B	D-SUB 25-pole, female	16
6	Modem Connection RS 232C	D-SUB 25-pole, female	9
7	Alarm Connection	D-SUB 9-pole, female	4

### 4.3.1 Integrated V.32 Telephone Modem

Communication:	Synchronous, V.32 or V.32bis
Speed:	Max. 9600 b/s (14 400 b/s for V.32bis)
Line type:	Two-wire, or four-wire, leased lines (see below)

BRU3 end connector: D-SUB 9-pole, male

#### Connector Specification:

Only the pins that are used are shown below.

Pin	Twist	Colour	Signal	Description
1	a	Brown	LRA	Leased Line, 4-wire, (RX)
2	a	Black	LRB	Leased Line, 4-wire, (RX)
3	b	Red	LT/2WA	Leased Line 4-wire transmit or Leased Line 2-wire (RX and TX)
4	b	Black	LT/ 2WB	Leased Line 4-wire transmit or Leased Line 2-wire (RX and TX)
6	c	Orange	SWA	Switch Line
7	c	Black	SWB	Switch Line

Fallback mode to switched telephone lines can be used.

**Note:** The information regarding telephone modems in this manual may not be applicable to all BRU3 variants.

### 4.3.2 Unbalanced serial port, RS 232C

Communication: Synchronous, serial

Speed: Max. 19.200 bps

Electrical: V.28

Logical: V.24

BRU3 end connector: D-SUB 25-pole, female

Max. dist. to DCE: 17 m (50 ft)

#### Connector Specification:

Only the pins that are used are shown below.

Pin	Twist	Colour	Signal	Description
1		Screen	GND (101)	Protective Ground
2	a	Brown	TX (103)	Transmit Data
3	b	Red	RX (104)	Receive Data
4	c	Orange	RTS (105)	Request to Send
7	a	Black	SGND (102)	Signal Ground
8	c	Black	DCD (109)	Data Carrier Detect
15	d	Yellow	TC (114)	Transmit Clock
NC	d	Black		
17	e	Green	RC (115)	Receive Clock
NC	e	Black		

20	f	Blue	DTR (108)	Data Terminal Ready
24	f	Black	ETC (113)	Ext. Transmit Clock

**Note:** To choose between RS 232C and RS 422B, use the SW2 dip switch on the FCB.



### 4.3.3 Balanced serial port, RS 422B

Communication:	Synchronous, serial
Speed:	Max. 64.000 bps
Electrical:	V.11 (EIA-422-A)
Logical signals:	V.24
BRU3 end connector:	D-SUB 25-pole, female
Max. dist. to DCE:	A few kilometres, depending on transmission speed and type of cable.

#### Connector Specification:

Only the pins that are used are shown below.

Pin	Twist	Colour	Signal	Description
1		Screen	GND (101)	Protective Ground
2	a	Brown	TX_A (103)	Transmit Data
3	b	Red	RX_A (104)	Receive Data
4	c	Orange	RTS_A (105)	Request to Send
8	d	Yellow	DCD_A (109)	Data Carrier Detect
9	d	Black	DCD_B (109)	Data Carrier Detect
11	a	Black	TX_B (103)	Transmit Data
12	b	Black	RX_B (104)	Receive Data

13	c	Black	RTS_B (105)	Request to Send
14	e	Green	TC_B (114)	Transmit Clock
15	e	Black	TC_A (114)	Transmit Clock
17	f	Blue	RC_A (115)	Receive Clock
19	f	Black	RC_B	Receive Clock
20	g	Violet	DTR_A (108)	Data Terminal Ready
22	g	Black	DTR_B (108)	Data Terminal Ready
23	h	Grey	ETC _B(113)	External Transmit Clock
24	h	Black	ETC _A(113)	External Transmit Clock

**Note:** To choose between RS 232C and RS 422B, use the SW2 dip switch on the FCB.

## 4.4 Connecting the Alarm

Electrical: 0.5 mA, 12 V

BRU3 end connector: D-SUB 9-pole, female

Max. dist. to DCE: 20 m (60 ft)

### Connector Specification:

Pin	Twist	Colour	Function	Description
1	a	Brown	VCC_EXT	Galvanic separated +12 V, Voltage Supply
2	a	Black	AL1+	Alarm Loop for customer's use
3	b	Red	AL1-	Alarm Loop for customer's use
4	b	Black	GND_EXT	Ground for VCC_EXT
5		Screen		
7		Black		Internal use. Not to be connected.
8		Yellow		Internal use. Not to be connected.

### 4.4.1 Alarm Loop for Customer's Use

The diagrams below show how the alarm loop can be used, with or without an internal power supply.

The circuit diagrams show the FE Connection Board (FNB) in the BRU3 and how the FE Alarm Cable is connected. In the examples, the switch could be replaced with any type of alarm equipment.

A parameter in the NMS Client is used to set the alarm to indicate whether the switch is open or closed.

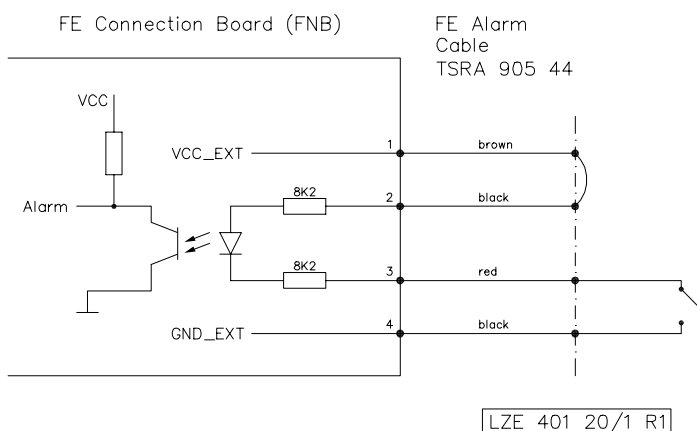

Figure 11 External alarm powered by the BRU3.

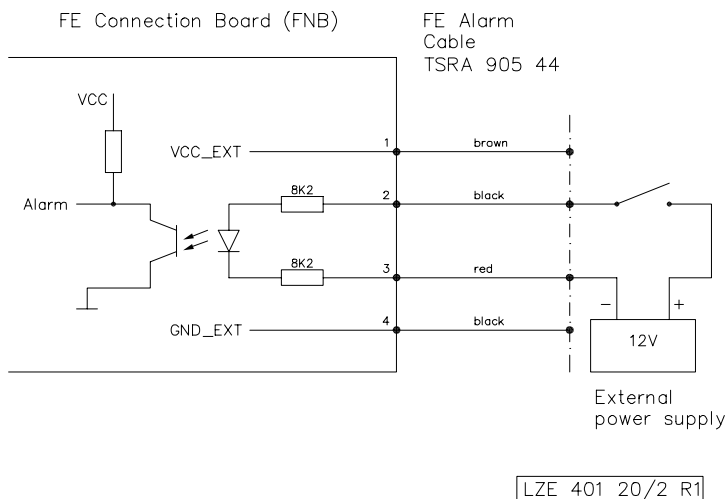

Figure 12 External alarm with external power supply.

## 4.5 Connecting the Antenna

The BRU3 has either a duplex filter or bandpass filters installed. The duplex filter makes it possible to use a combined Rx/Tx antenna, while the bandpass filters require separate Rx and Tx antennas.

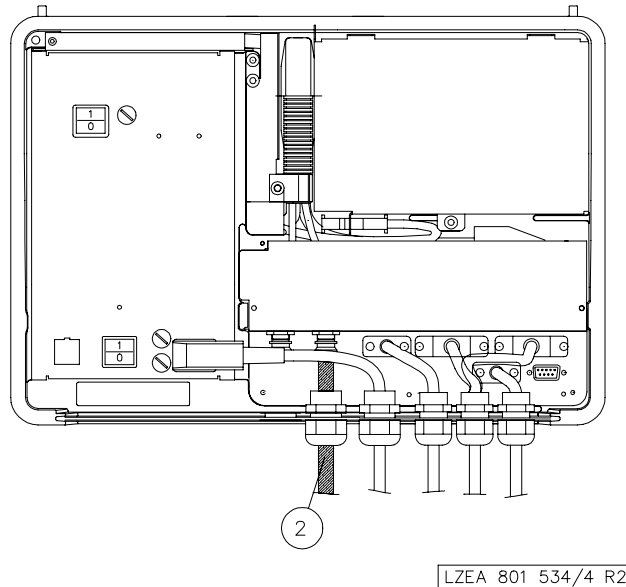
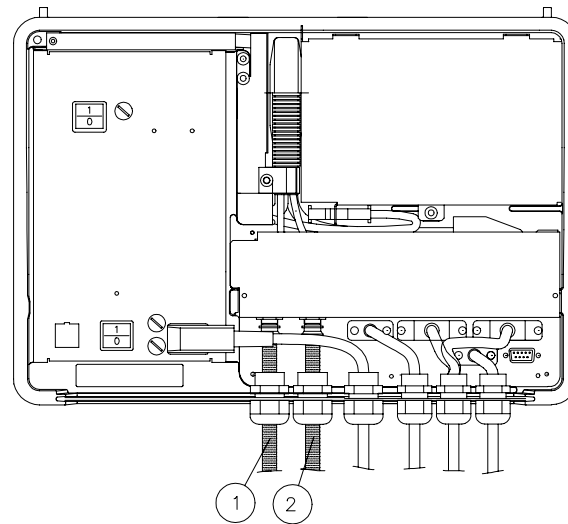

Figure 13 Connection for combined RX/TX antenna.

Pos.	Function	Connector	Cable
2	Antenna Connection	TNC-male	RG214/U-60



LZEA 801 534/3 R2

Figure 14 Connection for separate antenna.

Pos.	Function	Connector	Cable
1	Rx Antenna	TNC-male	RG214/U-60
2	Tx Antenna	TNC-male	RG214/U-60

---

## 5 Grounding

The grounding systems should meet the requirements of the national standards. It is the responsibility of the customer to ensure that the external grounding system at the site is adequate and that the grounding system for the equipment can easily and satisfactorily be connected to it.

When the BRU3 is installed, the ground cable should be connected to the Base Plate (as specified in the installation instructions), to which the BRU3 itself is grounded. The other end of the ground cable should be connected to the main station ground.

The grounding material needed includes a Copper Grounding Cable  $\geq 16\text{mm}^2$  (AWG 5) and a stainless Cable Lug (M8), to be provided by the customer. The M8 Grounding Bolt is included in the Installation Kit from Mobitex Technology AB.

For grounding of the antenna equipment, please refer to *Ground Connection* in the *Installation Instructions* section of the *BRU3 - Installation* module.

When the site has been prepared for installation, there should be a ground cable installed, ready to be connected to the BRU3 Base Plate.

## 6 Connecting Antenna Cables and Mounting Antennas

In case the antenna cable is longer than 5 m, a feeder is required as specified in the table below. Please refer to *Figure 15 “Antenna cable, shorter than 5 m.”* and *Figure 16 “Antenna cable, longer than 5 m.”* for mounting instructions.

	RG214/U-60 (jumper)	Flexwell 7/8" (feeder)	Flexwell 1 5/8" (feeder)
Impedance	50 ohms	50 ohms	50 ohms
Loss	22 dB/100 m	3.9 dB/100 m	2.1 dB/100 m
Max. dist. between clamps	1 m	1 m	1 m
Bending radius (minimum)	55 mm	250 mm	500 mm

It is recommended to have the antenna cable connectors sealed properly. Silicon grease and butyl rubber tape can be used to seal them. Total feeder loss is recommended to equal to or less than 2 dB.

The antenna foot must be grounded. If a feeder is used and if the antenna cable is longer than 5 m, the antenna cable connectors have to be grounded as shown in *Figure 16 “Antenna cable, longer than 5 m.”*

When the site has been prepared for installation, there should be a weather-protected antenna cable installed, ready to be connected to the BRU3.



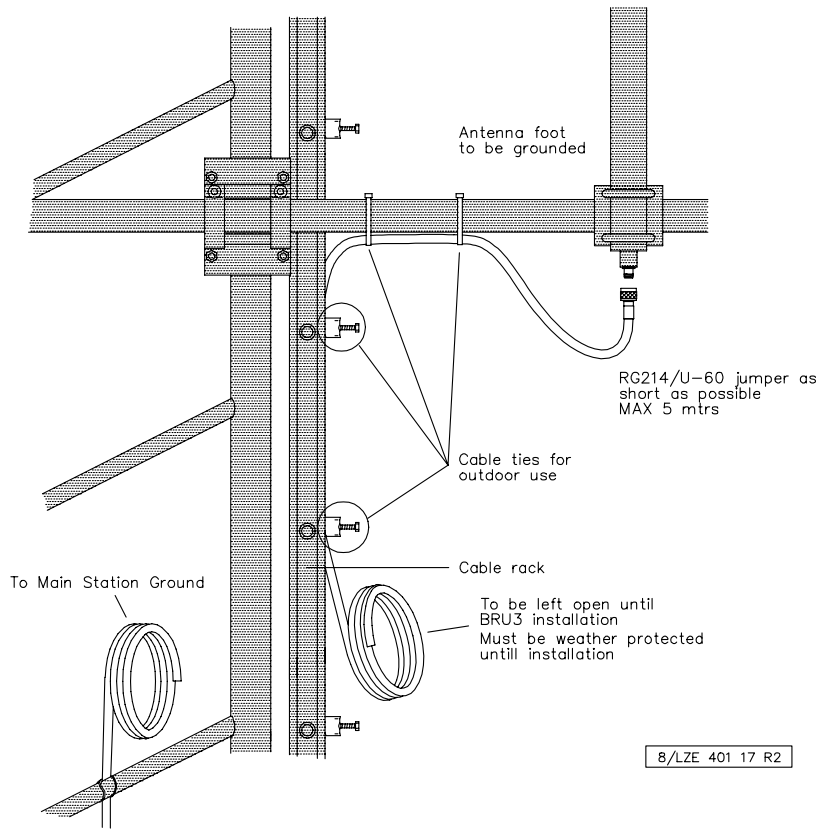

Figure 15 Antenna cable, shorter than 5 m.

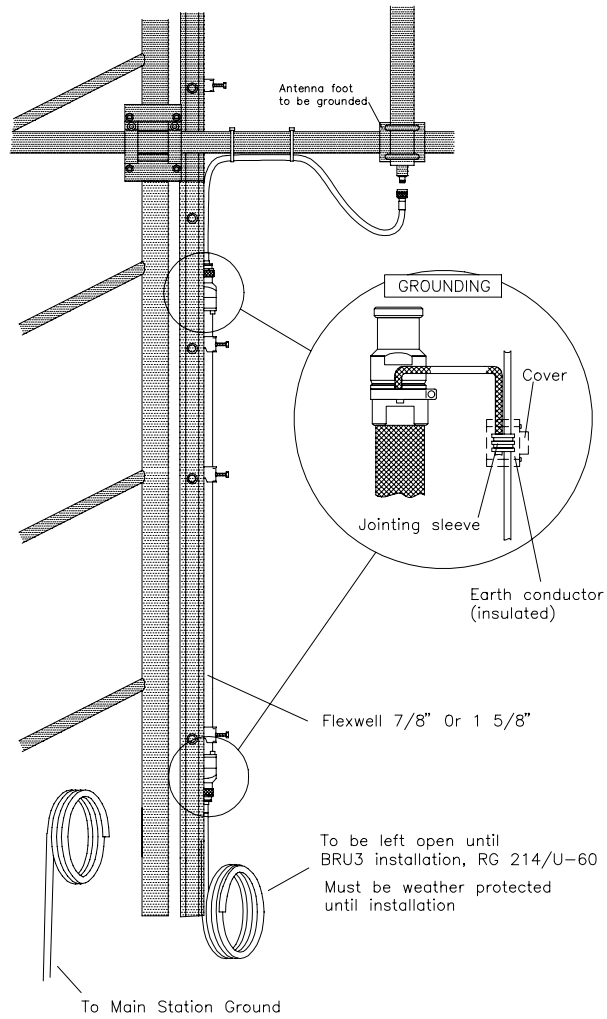

Figure 16 Antenna cable, longer than 5 m.

## **7**     **Lightning Protection**

The lightning protection systems should meet the requirements of the national standards. It is the responsibility of the customer to ensure that the existing lightning protection system at the site is adequate.

