

BRU1 - Site Requirements and Installation Instruction

Contents

1	Introduction	3
1.1	BRU1 Presentation	3
2	The BRU1 Delivery Specification	4
2.1	Standard Installation Equipment.....	4
2.2	Storage	4
2.3	Transport.....	4
3	Site Requirements	5
3.1	The Right Location	5
3.2	Environmental.....	5
3.3	RF Environment.....	5
3.4	Maintenance.....	6
3.5	Space Required	6
3.5.1	General	7
3.5.2	Above the BRU1	7
3.5.3	Below the BRU1.....	7
4	Preparations Before Installation.....	8
4.1	Not Included Installation Material (Provided by the Installation Contractor).....	8
4.2	Site Inspection.....	8
5	Installation of the BRU1	9
5.1	Installation of the BRU1 on a Wall	9
6	Cables and External Connections.....	12
6.1	General.....	12
7	Connecting Power	13
8	Connecting Network Communication.....	14
8.1	General.....	14
8.2	Connecting the Ethernet Port.....	14
8.2.1	Ethernet Port Pinout and Characteristics	15
8.3	Connecting the RS232C Line	16
8.3.1	RS232 Port Pinout and Characteristics.....	16
8.4	Connecting the RS422B Line	18
8.4.1	RS422B Port Pinout and Characteristics.....	18

9	Connecting the Console Port.....	20
9.1	RS232C (Console) Port Pinout and Characteristics.....	20
10	Connecting an External Alarm.....	22
10.1	Before Leaving the Site.....	24

Mobitex is a registered trademark of Mobitex Technology AB.

*The contents of this document are subject to revision without notice due to continued progress in methodology, design and manufacturing.
Mobitex Technology AB shall have no liability for any errors or damages of any kind resulting from the use of this document.*

1 Introduction

This document covers information about how to make the site preparations and how to install the Mobitex Base Radio Unit 1 (BRU1).

Before installation takes place the site must be prepared, this is important not only for a correct and safe installation, but also for saving time.

1.1 BRU1 Presentation

Base Radio Unit 1 (BRU1) is a complete one-channel compact radio base station which uses 8 kbps data signalling. The BRU1, which is intended for indoor operation, is a link between the mobile terminals and the area exchanges in the Mobitex Network. All parts are integrated in the unit, see *Figure 1*.

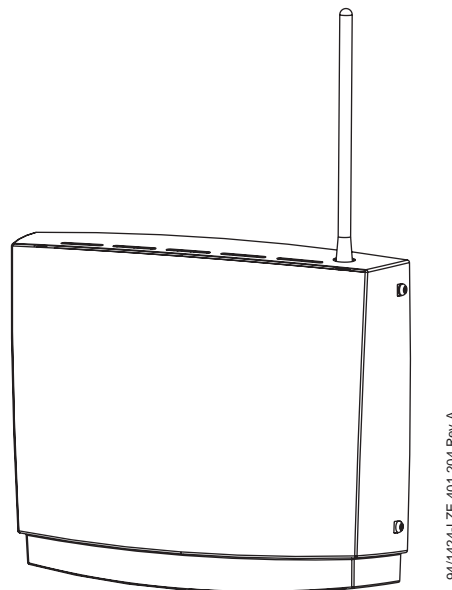

94/1424-LZE 401 2004 Rev A

Figure 1 BRU1

2 The BRU1 Delivery Specification

All BRU1 deliveries are packed according to the *BRU1 - Site Documentation* for the site.

Note: The *Site Documentation* is not included in the electronically published version of the *Mobitex NTE Client Library* but is delivered on paper together with the hardware.

2.1 Standard Installation Equipment

The BRU1 is delivered with an installation bracket which comprises all the parts needed to install the BRU1 on a wall, except for the installation material listed in *4.1 Not Included Installation Material (Provided by the Installation Contractor)*.

2.2 Storage

The delivery package for the BRU1 meets standard ETS 300 019-1-1, class 1.2 for storage. However, it is recommended to have any plans for long term storage verified by Mobitex Technology.

2.3 Transport

The BRU1 is to be transported in accordance with the ETSI EN 300 019-1-2 standard, class 2.3 for public transportation.

3 Site Requirements

3.1 The Right Location

The right location for the BRU1 is where the following conditions can be met:

- Environmental requirements
- RF environment requirements
- Maintenance requirements

3.2 Environmental

The unit shall be located in a well-ventilated area protected from extreme temperature fluctuations, dust and water. The unit shall also be protected against direct sunlight. To allow proper airflow around the unit, please follow the recommendation in this chapter.

3.3 RF Environment

The unit shall be located in a position where good radio coverage can be provided. For safety reason it is important that users cannot touch the antenna or approach the antenna near field. If another antenna than the delivered is used, please keep in mind that the BRU1 is an indoor equipment only. Do not mount the antenna outdoor, where it can be exposed to lightning.

Warning: To satisfy the FCC RF exposure requirements for base station transmitting devices, a separation distance should be maintained between the antenna of this device and persons during device operation as described in *Node Hardware Library/BRU1/Safety Instructions*. Changes or modifications violating these instructions can void the user's authority to operate the equipment.

Note: The equipment has been tested and found to comply with the limits of a Class B digital device, pursuant to part 15 of the FCC rules. These limits are designed to provide reasonable protection against harmful interference in a residential installation. The equipment generates, uses and can generate radio frequency energy, and if not installed and used in accordance with the instructions, may cause harmful interference to radio communications. However, there is no guarantee that interference will occur in a particular installation. If this equipment does cause harmful interference to radio or television reception, which can be determined by turning the equipment on and off, the user is encouraged to try to correct the interference by one or more of the following measures:

- Increase the separation by relocating the unit or the transmitting antenna.
- Connect the equipment into an outlet with a separate circuit (if an AC/DC converter is used).

3.4 Maintenance

For maintenance reason it is important to have easy access to the connectors. Please follow the recommendations in this chapter.

3.5 Space Required

When deciding where to install the BRU1, it is important to keep the following in mind:

- The BRU1 must be installed where the delivered antenna gives a good indoor coverage.
- Accessibility must be maintained to allow installation and maintenance.
- The site shall provide an ambient temperature preventing the BRU1 to exceed its maximum operation temperature. The ambient temperature shall be measured 100 mm below the BRU1.

The space required for a BRU1 is shown in *Figure 2*. Also refer to the text below for further information.

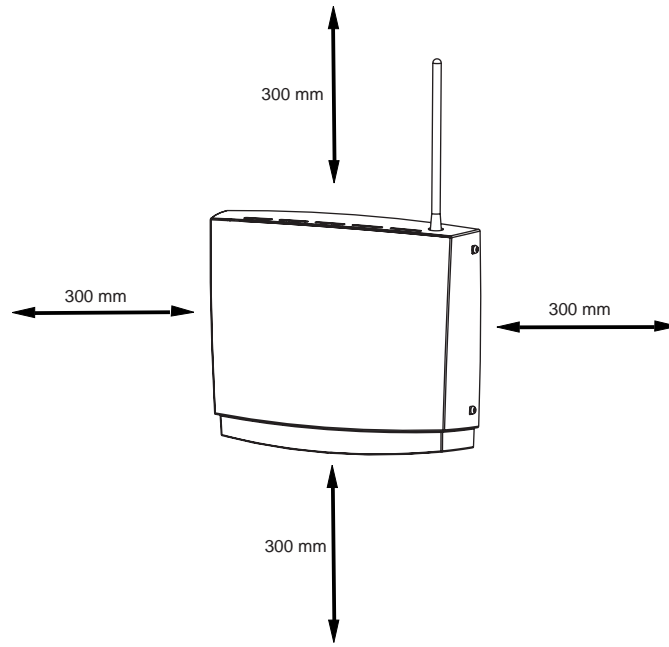

Figure 2 Space required.

3.5.1 General

The space specified in this document is a minimum to allow an adequate airflow around the equipment. The customer decides if any additional working space is needed around the BRU1. The BRU1 can be mounted in two directions, either with the antenna facing up, or with the antenna facing down. The building material in the walls and ceiling may interfere with the antenna and the position of the BRU1 must therefore be made carefully.

3.5.2 Above the BRU1

Minimum: 300 mm

A minimum of 300 mm free space is necessary above the case.

3.5.3 Below the BRU1

Minimum: 300 mm

To be able to run the cables safely, 300 mm of free space is necessary below the case. The distance also allow an adequate airflow around the equipment.

4 Preparations Before Installation

Generally, the BRU1 can be installed at most indoor locations. However, it is important that the BRU1 is always mounted for optimal indoor coverage and good ventilation.

On delivery, all mounting components except screws are delivered together with the BRU1.

4.1 Not Included Installation Material (Provided by the Installation Contractor)

Make sure that the following required installation material is available before the installation work is started. Check as follows:

- 3 pcs of screws for installation of the BRU1 Base Plate.
Size of screws/plugs depending on wall material. Please consider the BRU1 weight of 4 kg.
- A +24V power connection/cable.
- 1 pc of console cable.
- 1 pc of network cable (RS232/RS422 or Ethernet)
- *BRU1 - Site Documentation*.

Note: The *Site Documentation* is not included in the electronically published version of the *Mobitex NTE Client Library* but is delivered on paper together with the hardware.

4.2 Site Inspection

Before the installation can begin the site must have been prepared according to *3 Site Requirements* in this document.

- Check that the BRU1 site is prepared for installation.
- Check that the required +24V, 2A, connection is available.
- Check that all cables provided by the customer are in position and ready to be connected to the BRU1.
- Check that the site network connection has been routed to the BRU1.

5 Installation of the BRU1

5.1 Installation of the BRU1 on a Wall

1. Unpack the BRU1 equipment. Tick off all parts against the delivery note. Please report missing or damaged parts to the shipper.
2. Mark the positions of three holes using the base plate. Drill the three holes in the wall with an appropriate dimension, see *Figure 4*.

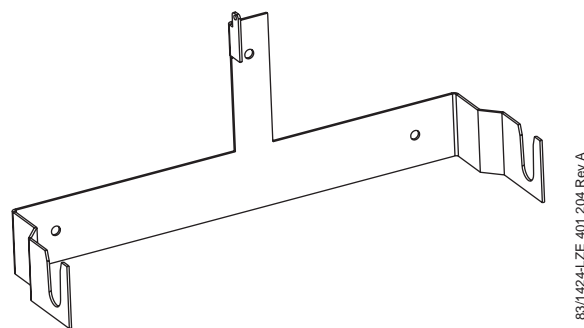

Figure 3 BRU1 base plate.

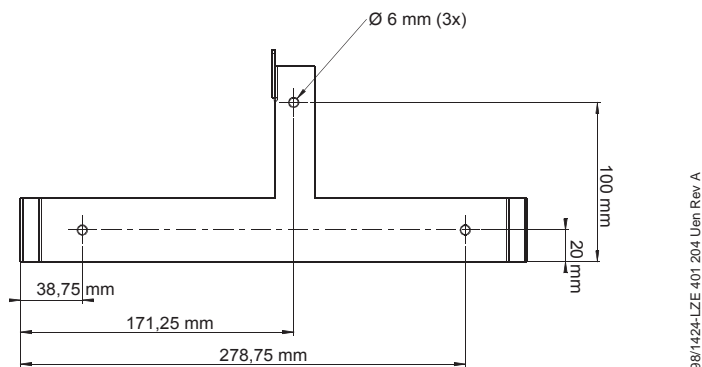
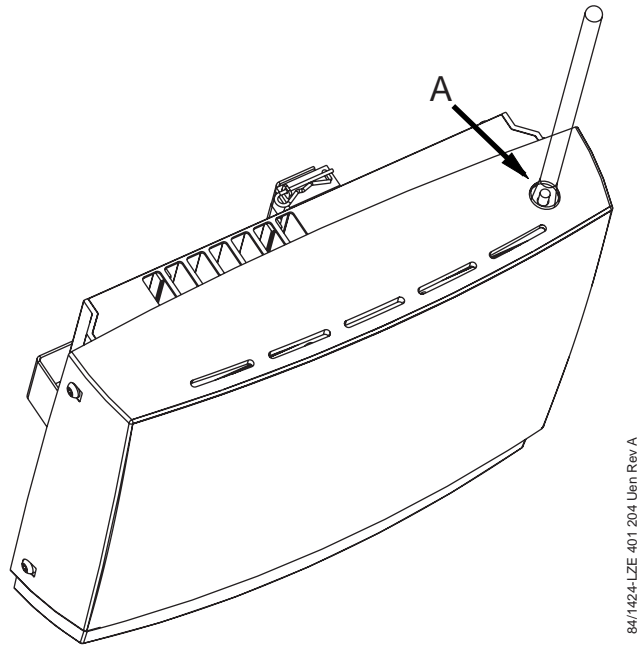

Figure 4 BRU1 base plate dimensions.

3. Install the base plate on the wall (type of screws and plugs depends on the wall material and the BRU1 weight of 4 kg.).



84/1424-LZE 401 204 Uen Rev A

Figure 5 Antenna SMA connector.

4. Install the delivered antenna to the SMA connector (A) of the BRU1. (See Figure 5).

Warning: If the delivered antenna is replaced or relocated with an antenna device with different characteristics please follow the instructions given in 3.3 *RF Environment*.

- Lift the BRU1 (see *Figure 6*). Put the two hook-up plastic wheels (B) into the openings in the base plate and let the BRU1 slide down into position.

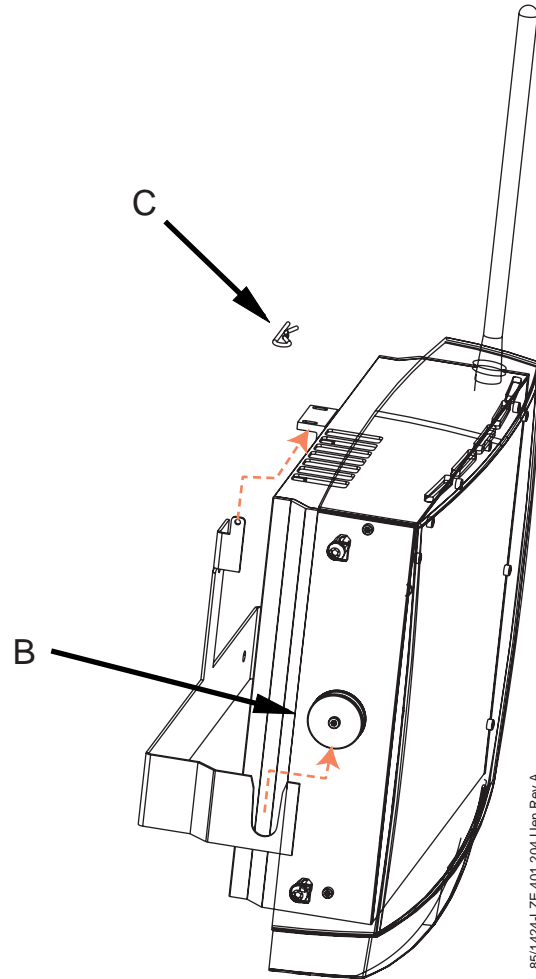

Figure 6 Mounting instruction.

- Fasten the locking pin (C).

6 Cables and External Connections

6.1 General

All cables provided by the customer must be in position and ready to be connected to the BRU1 before the installation takes place.

Only one of the line communication cables may be used.

Figure 7 shows where to connect the BRU1 cables. Use the figure to plan the cable arrangements. The types of connector mentioned in the following sections always correspond to the cable connector of the BRU1.

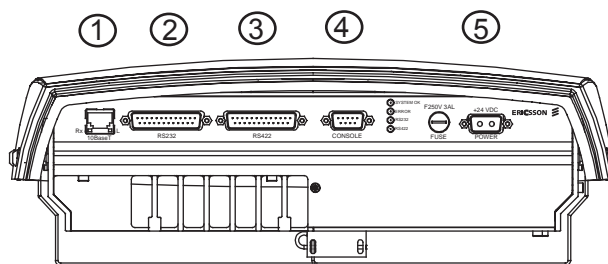

8771424-LZE-401 2004 Uen Rev A

Figure 7 BRU1 external connections.

Pos. Function

- | | |
|---|---|
| 1 | Ethernet RJ-45 connector |
| 2 | Modem connection RS 232C |
| 3 | Modem connection RS 422B |
| 4 | Console connection (incl. one external alarm) |
| 5 | Power connection |

7 Connecting Power

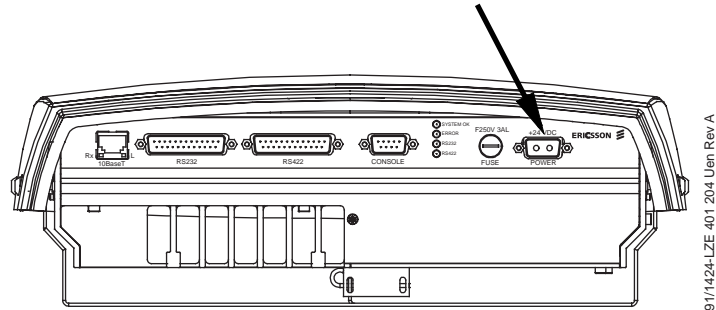

Figure 8 Power connector.

The BRU1 power connector is a 2-pin Mixed DSUB connector. A power cable with connector type F2W2SC-0439 from FCT Electronics may be used. Locate the power connector (see *Figure 8*) and connect the power.

Connector Specification:

Pin	Signal	Description
1	+24V	+24V
2	GND	Ground

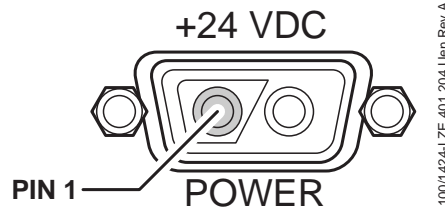

Figure 9 Detail of pin location on the BRU1.

8 Connecting Network Communication

8.1 General

There are three network connection alternatives for connecting the BRU1 to the Mobitex Area Exchange (MOX). One of the following shall be used:

- Ethernet (10Base-T)
- RS232C line connection
- RS422B line connection

8.2 Connecting the Ethernet Port

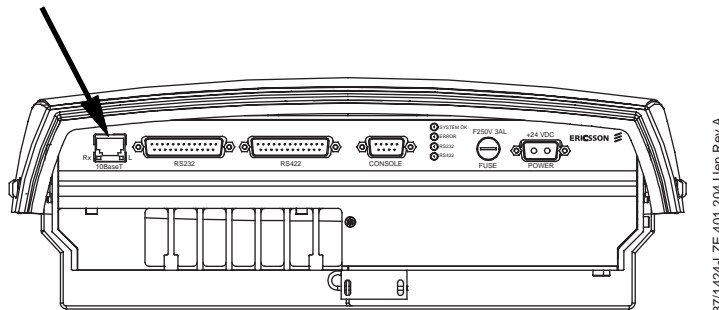

Figure 10 Ethernet (10Base-T) port.

Locate the Ethernet RJ-45 connector (see *Figure 10*) and connect the Ethernet cable.

8.2.1 Ethernet Port Pinout and Characteristics

Electrical: 10Base-T (using twisted pair cable)

BRU1 end
connector: RJ-45

Max. dist. 50 m with AWG 24 cable (164 ft)

Connector Specification:

Pin	Twist	Function	Description
1	a	TX+	Transmit +
2	a	TX-	Transmit -
3	b	RX+	Receive +
4		NC	
5		NC	
6	b	RX-	Receive -
7		NC	
8		NC	

8.3 Connecting the RS232C Line

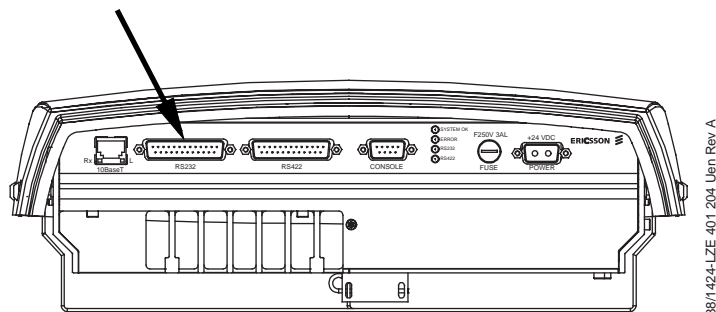

Figure 11 RS232C connector.

Locate the RS232 connector (see *Figure 11*) and connect the cable.

8.3.1 RS232 Port Pinout and Characteristics

Communication: Synchronous, serial

Speed: Max. 19.200 bps

Electrical: V.28

Logical: V.24

BRU1 end connector: D-SUB 25-pole, female

Max. dist. to DCE: 17 m (50 ft)

Connector Specification:

Only the pins that are used are shown below.

Pin	Twist	Signal	Description
1		GND (101)	Protective Ground
2	a	TX (103)	Transmit Data
3	b	RX (104)	Receive Data
4	c	RTS (105)	Request to Send
7	a	SGND (102)	Signal Ground
8	c	DCD (109)	Data Carrier Detect
15	d	TC (114)	Transmit Clock
17	e	RC (115)	Receive Clock
20	f	DTR (108)	Data Terminal Ready
24	f	ETC (113)	Ext. Transmit Clock

8.4 Connecting the RS422B Line

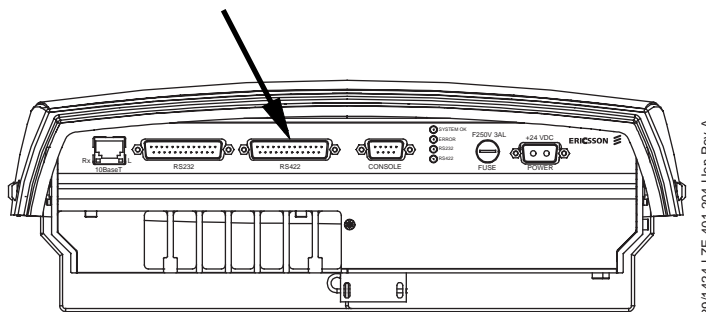

Figure 12 RS422 connector.

Locate the RS422 connector (see *Figure 12*) and connect the cable.

8.4.1 RS422B Port Pinout and Characteristics

Communication:	Synchronous, serial
Speed:	Max. 64.000 bps
Electrical:	V.11 (EIA-422-A)
Logical signals:	V.24, RS-530 standard
BRU1 end connector:	D-SUB 25-pole, female
Max. dist. to DCE:	A few kilometres, depending on transmission speed and type of cable.

Connector Specification:

Only the pins that are used are shown below.

Pin	Twist	Signal	Description
1		GND (101)	Protective Ground
2	a	TX_A (103)	Transmit Data A
3	b	RX_A (104)	Receive Data A
4	c	RTS_A (105)	Request to Send A
7	i	SGND (102)	Signal Ground
8	d	DCD_A (109)	Data Carrier Detect A
9	f	RC_B (115)	Receive Clock B
10	d	DCD_B (109)	Data Carrier Detect B
11	h	ETC_B(113)	External Transmit Clock B
12	e	TC_B (114)	Transmit Clock B
14	a	TX_B (103)	Transmit Data B
15	e	TC_A (114)	Transmit Clock A
16	b	RX_B (104)	Receive Data B
17	f	RC_A (115)	Receive Clock A
19	c	RTS_B (105)	Request to Send B
20	g	DTR_A (108)	Data Terminal Ready A
23	g	DTR_B (108)	Data Terminal Ready B
24	h	ETC_A(113)	External Transmit Clock A

9 Connecting the Console Port

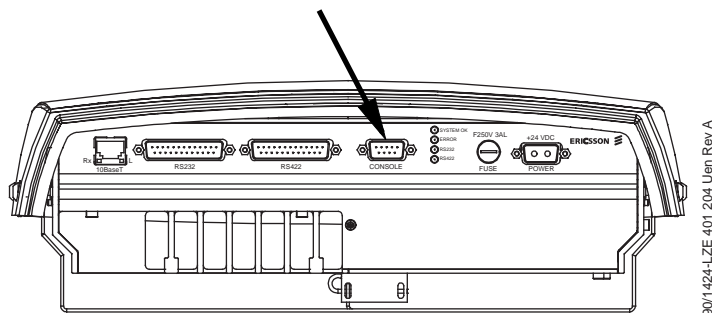

Figure 13 9 pin console connector:

Locate the 9 pin RS232C connector (see *Figure 13*) and connect the cable.

9.1 RS232C (Console) Port Pinout and Characteristics

Communication:	Asynchronous, serial
Speed:	Max. 115 200 bps
Electrical:	V.28
Logical:	V.24
BRU1 end connector:	D-SUB 9-pole, female
Max. dist. to DCE:	17 m (50 ft)

Connector Specification:

Only the pins that are used are shown below.

Pin	Signal	Description
1	GND	Protective Ground
2	RX	Receive data
3	TX	Transmit data
4	DTR	Data Terminal Ready (+12V)
5	SGND	Signal Ground
7	PROD_TEST	For Mobitex Technology internal use
8	AL -	External alarm -
9	AL +	External alarm +

10 Connecting an External Alarm

It is possible to connect one external alarm to the BRU1. The connecting procedure depends on whether the current loop is supplied with power from the BRU1 or from an external power supply.

The following alarm connection data are given:

- Internal Resistance = 16.4 kohm
- Type Current = 0.5 mA
- Minimum Current = 0.1 mA
- Voltage = 12 V

Connect the external alarm according to the following two alternatives:

Alternative 1: Connection of external alarm with current loop powered by using the DTR pin in the console cable.

Strap connector pins according to the drawing below.

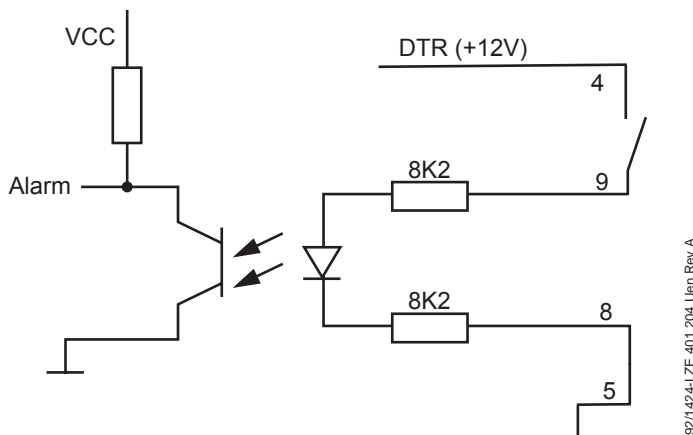
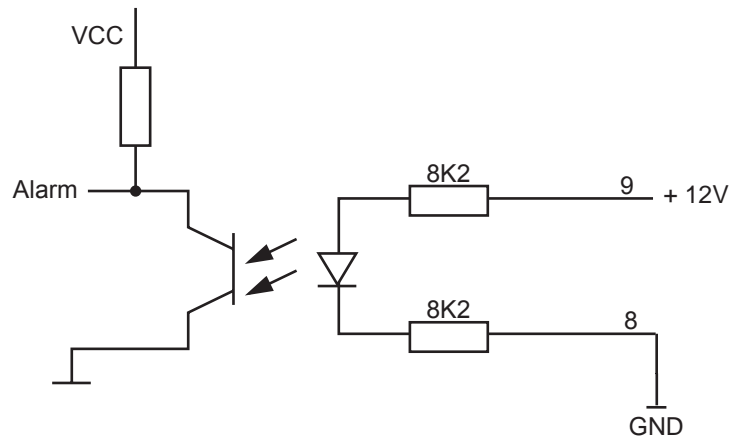

Figure 14 Passive external alarm connection.

Alternative 2: Connection of external alarm with current loop powered by external power supply.

The diagram below show how the alarm loop can be used.



93/1424-LZE 401 204 Uen Rev A

Figure 15 Active external alarm connection.

11 Before Leaving the Site

The BRU1 installation is now completed. Please continue with the hardware and software commissioning procedures described in *Node Hardware Library/BRU1/Commissioning Procedure*.